

# DENALI™

LAH.07.10700

## AUXILIARY LIGHT MOUNT

BMW

R1200RT

2014 - 2017

### Thank you for choosing DENALI

We know you would rather be riding your bike than wrenching on it, so we go the extra mile to make sure our instructions are clear and as easy to understand as possible. If you have any questions, comments, or suggestions don't hesitate to give our gear experts a call at 401.360.2550 or visit DenaliElectronics.com

### Please Read Before Installing

DENALI products should always be installed by a qualified motorcycle technician. If you are unsure of your ability to properly install a product, please have the product installed by your local motorcycle dealer. DENALI takes no responsibility for damages caused by improper installation. **Caution:** When installing electronics it is extremely important to pay close attention to how wires are routed, especially when mounting products to the front fender, front forks, or fairing of your motorcycle. Always be sure to turn the handlebars fully left, fully right, and fully compress the suspension to ensure the wires will not bind and have enough slack for your motorcycle to operate properly.

### Installation Tips

We strongly recommend using medium strength liquid thread locker on all screws, nuts, and bolts. It is also important to ensure that all hardware is tightened to the proper torque specifications as listed in your owner's manual. For included accessory hardware please refer to the default torque specifications provided below. Inspect all hardware after the first 30 miles to ensure proper torque specifications are maintained.

Bolt Size	in-lbs	ft-lbs	Nm
M3	10.0 in-lbs	-	1.0 Nm
M4	23.0 in-lbs	-	2.5 Nm
M5	44.5 in-lbs	3.5 ft-lbs	5.0 Nm
M6	78.0 in-lbs	6.5 ft-lbs	9.0 Nm
M8	-	13.5 ft-lbs	18.0 Nm
M10	-	30.0 ft-lbs	41.0 Nm
M12	-	52.0 ft-lbs	71.0 Nm

### Hardware Sizing Guide

Not sure what size bolt you have? Use this ruler to measure screws, bolts, spacers, etc. Remember, the length of a screw or bolt is measured from the start of the "mounting surface" to the end of the screw, so only include the screw head when measuring countersunk screws.

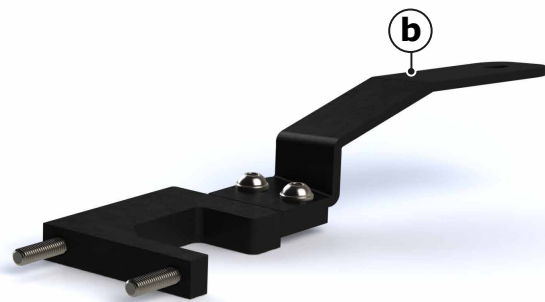
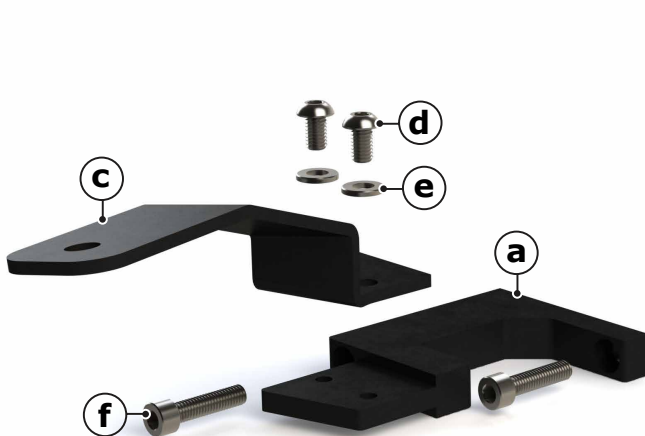
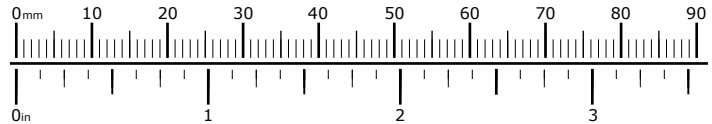

### Kit Contents

- (a) Machined Adapter.....Qty 2
- (b) RHS Bracket.....Qty 1
- (c) LHS Bracket.....Qty 1
- (d) M6x10 ISO 7380.....Qty 4
- (e) M6 Washer DIN 125.....Qty 4
- (f) M6x25 DIN 912.....Qty 4

### Tools Required

- 5mm Allen Key
- 4mm Allen Key
- T 30 Torx
- T 25 Torx

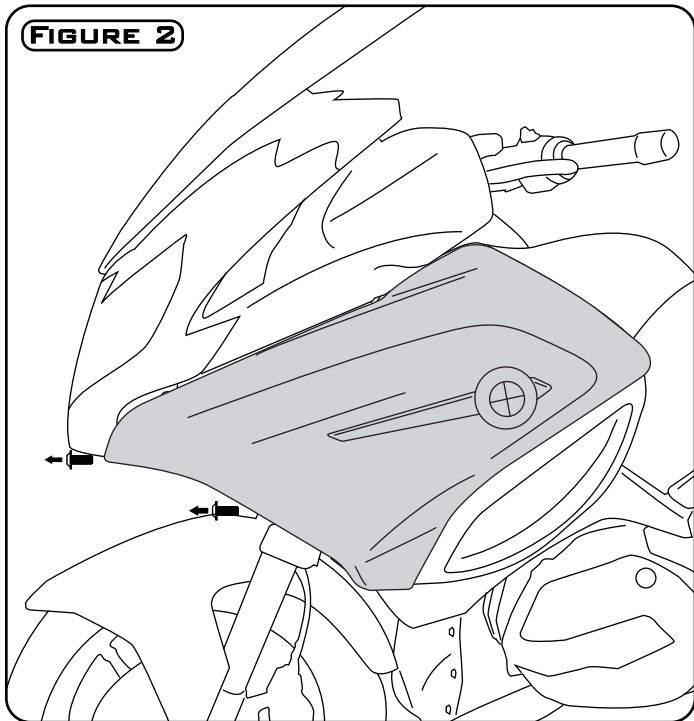

### Removing The OEM Bolts

**Step One:** Remove the two OEM bolts from the inner side of the left side fairing using a T-25 Torx tool.

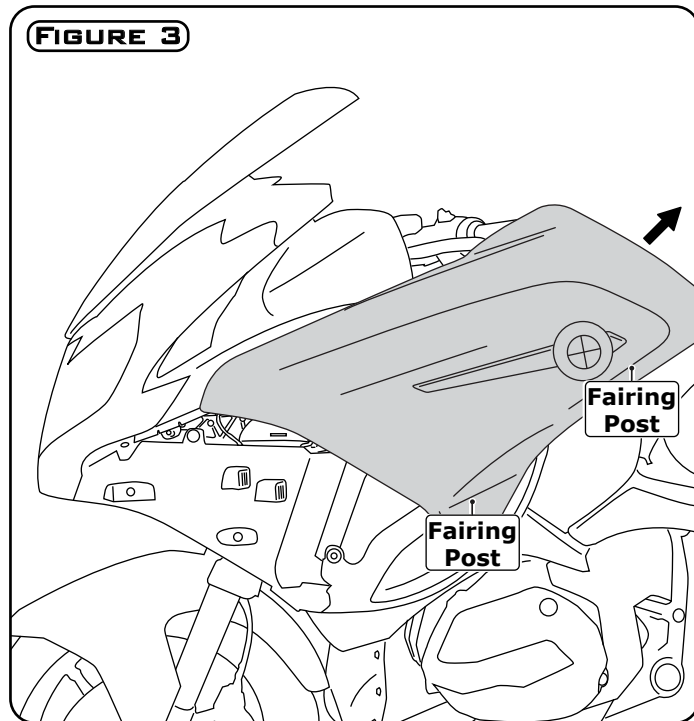

### Removing The Fairing

**Step Two:** Gently pull outwards on the lower edge of the fairing to pop out the two fairing posts from the rubber grommets.

**Step Three:** Once the fairing post have been released, pull the fairing up and towards the rear of the bike to remove the fairing from the motorcycle.

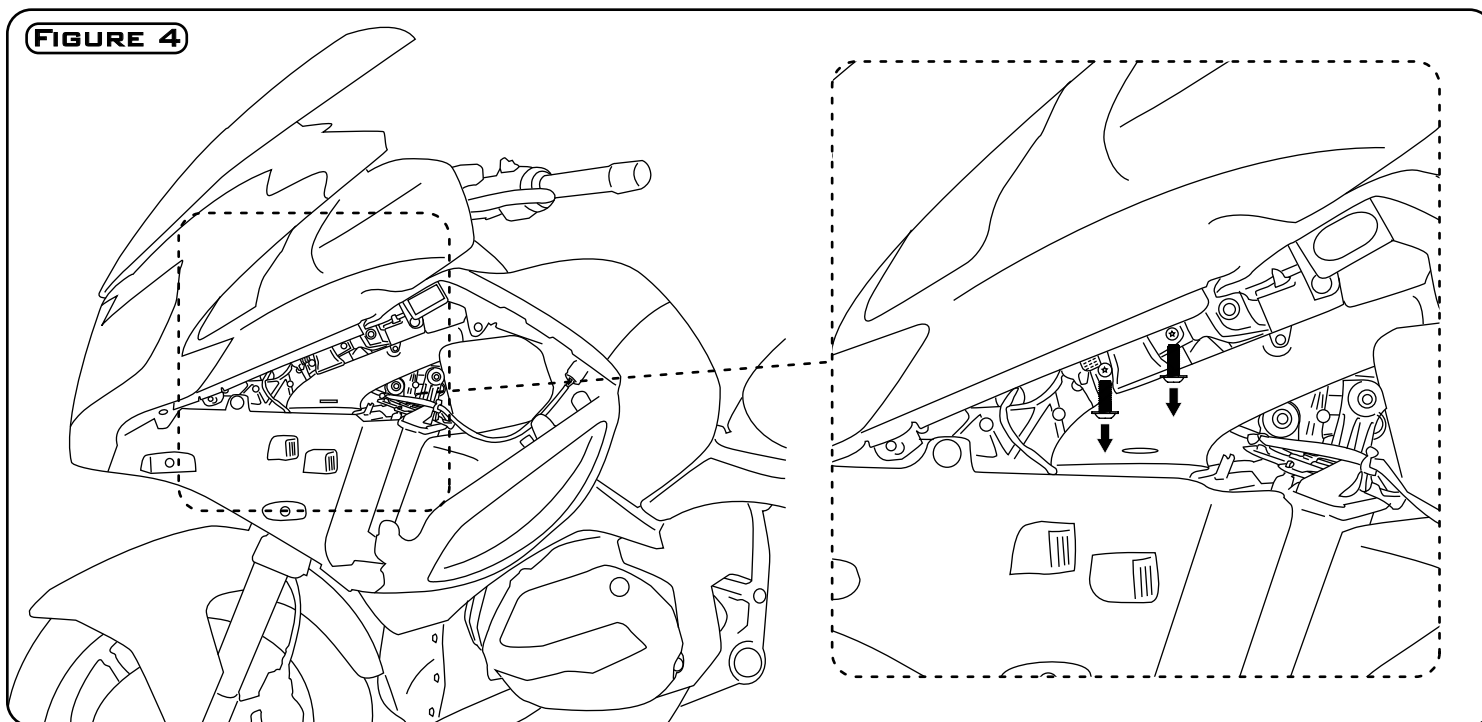

### Removing The OEM Bolts

**Step Four:** Use an T-30 Torx tool to remove the two OEM bolts located directly behind the air intake duct's mounting point.

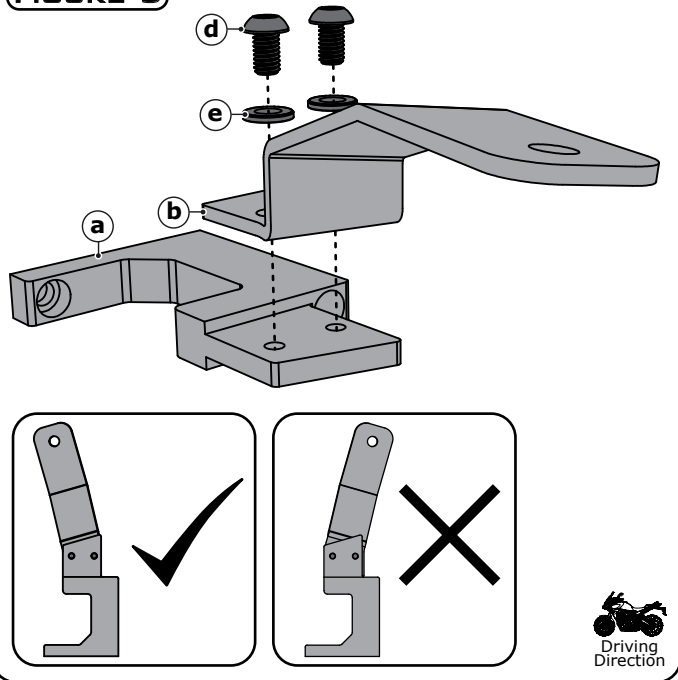
**FIGURE 5**

### Assembling The Light Mount (LHS Illustrated)

**Step Five:** Use an 4mm allen key, two M6x10 bolts (d) and two M6 washers (e) to attach the LHS bracket (b) to the machined adapter (a).

**Note:** Reference the two images above to determine if the light mount has been assembled correctly. The profile of the sheet metal bracket will match the profile/angle of the machined adapter when assembled correctly.

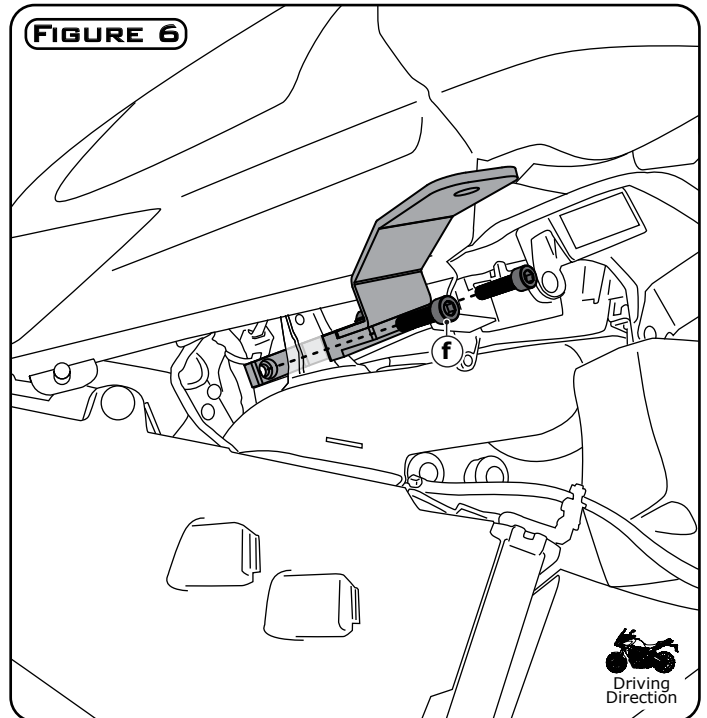
**FIGURE 6**

### Installing The Light Mount (LHS Illustrated)

**Step Six:** Maneuver the assembled light mount into position behind the air intake duct, aligning the mounting holes to same points the OEM bolts were removed from in *Figure Four*.

**Step Seven:** Use an 5mm allen key and two M6x25 bolts (f) to attach the assembled light mount to the motorcycle.

**Step Eight:** Repeat steps 1-7 on the right side of the motorcycle to complete the install.

**Step Nine:** Before operating the motorcycle, turn the handlebars fully left, fully right and fully compress the suspension. Confirm that the lights do not interfere with operation and that the wires have enough slack to account for all suspension and steering movement.